

# Specifications: Model 300 NPT Valve

## Horizontal Flow

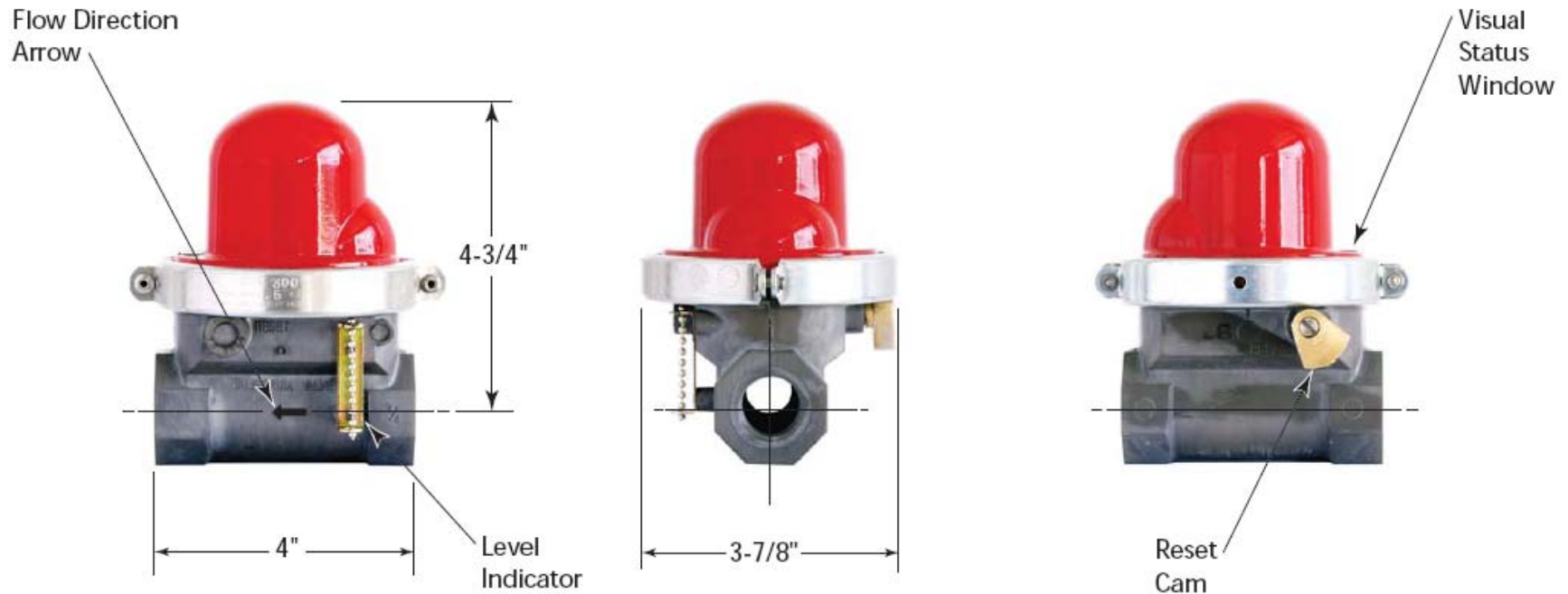

Valve Model#	CA-DSA No.	Length	Height	Width	Nominal Pipe Size	Threads Per Inch	APPLICATION	DATA
							Max. Pressure	Fuel
300	04R-30R	4"	4-3/4"	3-7/8"	3/4"	14	7.0 psi	Dry Fuel Gas

California Valves are UL-listed in the USA & Canada, certified by California's Division of the State Architect, Approved by Los Angeles, and warranted free of manufacturer's defects for 30 years (when used in the USA or Canada). California Valves meet California Standard 12-16-1 for Earthquake Actuated Automatic Gas Shutoff Systems & ASCE Standard 25-97 for Earthquake Actuated Automatic Gas Shutoff Devices.

**Distributed by Strand Earthquake Consultants**  
**Tel: (310) 473-2426 or 473-2316. Toll free: (800) 978-7263**  
**Fax: (310) 473-1366. Website: [www.strandearthquake.com](http://www.strandearthquake.com)**  
**1436 S. Bentley Ave., Suite #6, Los Angeles, CA 90025 USA**  
**Manufactured by Pacific Seismic Products, Inc.**

# 3/4" Model 300 California Seismic Valve Threaded Horizontal

## FLOW CAPACITY TABLE IWC/PSIG - Capacity S.C.F.H.

Merit Rating: Cv 21 (Equivalent Length of Pipe is 3 Feet)

For determining approximate values at selected natural gas pressures to

Pressure Drop		8" iwc Inlet	14" iwc Inlet	3 psi Inlet	5 psi Inlet	Pressure Drop		B. T. U. per Hour	
						PSI	IWC	8" iwc Inlet	14" iwc Inlet
.0036	0.1	362	365	393	415	.0036	0.1	362,000	365,000
.0072	0.2	512	516	556	587	.0072	0.2	512,000	516,000
.0108	0.3	627	631	681	718	.0108	0.3	627,000	631,000
.0144	0.4	724	729	786	829	.0144	0.4	724,000	729,000
.0180	0.5	809	815	879	927	.0180	0.5	809,000	815,000
.0216	0.6	886	893	963	1,016	.0216	0.6	886,000	893,000
.0252	0.7	957	964	1,040	1,097	.0252	0.7	957,000	964,000
.0288	0.8	1,023	1,031	1,111	1,173	.0288	0.8	1,023,000	1,031,000
.0324	0.9	1,085	1,093	1,179	1,244	.0324	0.9	1,085,000	1,093,000
.0360	1.0	1,144	1,152	1,242	1,311	.0360	1.0	1,144,000	1,152,000
.0720	2.0	1,616	1,627	1,755	1,852	.0720	2.0	1,616,000	1,627,000
.1080	3.0	1,976	1,990	2,147	2,286	.1080	3.0	1,976,000	1,990,000
.1440	4.0	2,279	2,296	2,477	2,614	.1440	4.0	2,279,000	2,296,000
.1800	5.0	2,545	2,564	2,767	2,920	.1800	5.0	2,545,000	2,564,000



## Horizontal Valves

		Sizes Available														Ambient Temperature
		NPT							Flanged							
		3/4"	1"	1 1/4"	1 1/2"	2"	2 1/2"	3"	4"	2"	2 1/2"	3"	4"	6"	8"	
Maximum Pressures of Available Sizes	7 psi	✓	✓	✓	✓											UL -40° to 150° F CA DSA: -10° to 150°F
	60 psi	✓	✓	✓	✓	✓	✓	✓	✓	✓	✓	✓	✓	✓	Fluid	
																Natural gas LP gas

Distributed by Strand Earthquake Consultants / Manufactured by Pacific Seismic Products, Inc.

Tel: (310) 473-2426 or 473-2316. Toll free: (800) 978-7263. Fax: (310) 473-1366. Website: [www.strandearthquake.com](http://www.strandearthquake.com)