

Specifications: Model 313(60) NPT Valve

Horizontal Flow

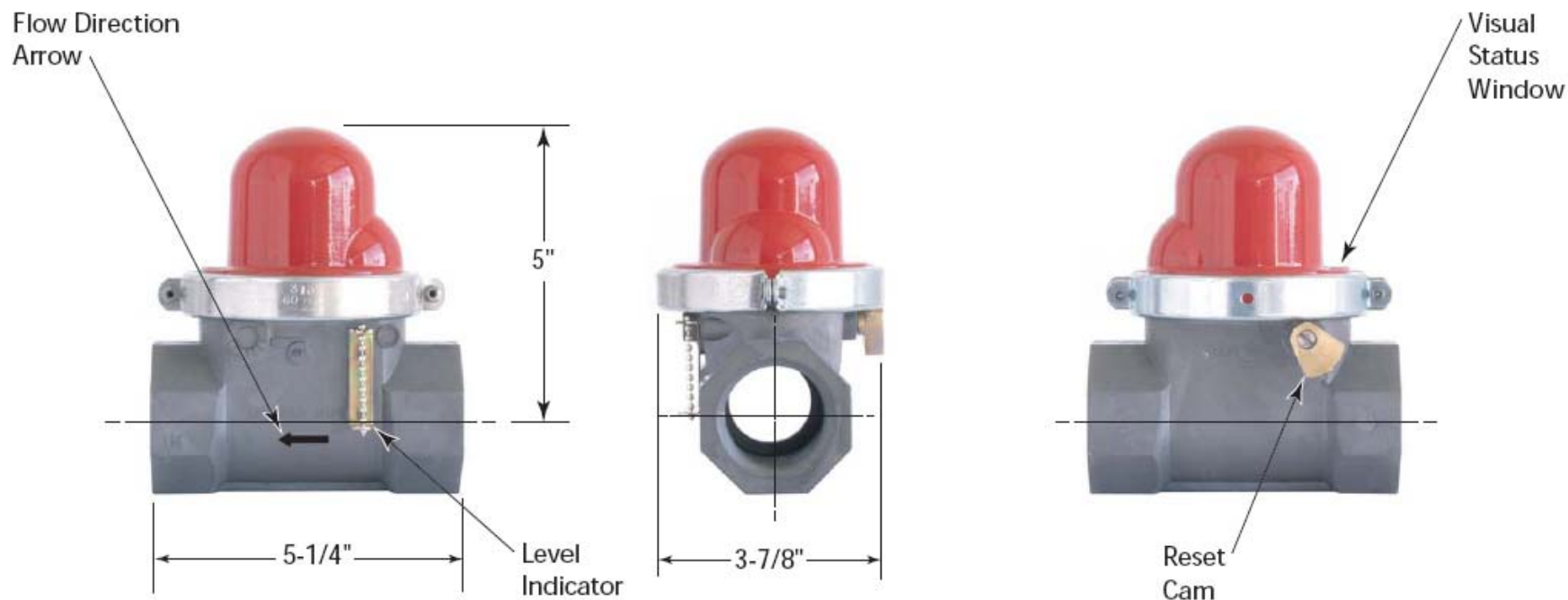

| Valve Model# | CA-DSA No. | Length | Height | Width | Nominal Pipe Size | Threads Per Inch | APPLICATION | DATA |
|--------------|------------|--------|--------|--------|-------------------|------------------|---------------|--------------|
| | | | | | | | Max. Pressure | Fuel |
| 313 | 45R-113R | 5-1/4" | 5" | 3-7/8" | 1-1/2" | 11-1/2 | 60 psi | Dry Fuel Gas |

California Valves are UL-listed in the USA & Canada, certified by California's Division of the State Architect, Approved by Los Angeles, and warranted free of manufacturer's defects for 30 years (when used in the USA or Canada). California Valves meet California Standard 12-16-1 for Earthquake Actuated Automatic Gas Shutoff Systems & ASCE Standard 25-97 for Earthquake Actuated Automatic Gas Shutoff Devices.

Distributed by Strand Earthquake Consultants
Tel: (310) 473-2426 or 473-2316. Toll free: (800) 978-7263
Fax: (310) 473-1366. Website: www.strandearthquake.com
1436 S. Bentley Ave., Suite #6, Los Angeles, CA 90025 USA
Manufactured by Pacific Seismic Products, Inc.

1-1/2" Model 313 California Seismic Valve Threaded Horizontal

FLOW CAPACITY TABLE IWC/PSIG - Capacity S.C.F.H.

Merit Rating: Cv 101 (Equivalent Length of Pipe is 5 Feet)

For determining approximate values at selected natural gas pressures to 60 PSIG

| Pressure Drop | | 8" iwc Inlet | 14" iwc Inlet | 3 psi Inlet | 5 psi Inlet | 7 psi Inlet | 10 psi Inlet | 20 psi Inlet | 60 psi Inlet |
|---------------|-----|--------------|---------------|-------------|-------------|-------------|--------------|--------------|--------------|
| PSI | IWC | | | | | | | | |
| .0036 | 0.1 | 1,741 | 1,754 | 1,891 | 1,995 | 2,094 | 2,234 | 2,648 | 3,886 |
| .0072 | 0.2 | 2,462 | 2,480 | 2,674 | 2,821 | 2,961 | 3,159 | 3,745 | 5,495 |
| .0108 | 0.3 | 3,015 | 3,037 | 3,275 | 3,455 | 3,627 | 3,869 | 4,586 | 6,730 |
| .0144 | 0.4 | 3,454 | 3,478 | 3,781 | 3,989 | 4,187 | 4,468 | 5,296 | 7,771 |
| .0180 | 0.5 | 3,892 | 3,920 | 4,227 | 4,460 | 4,681 | 4,994 | 5,921 | 8,688 |
| .0216 | 0.6 | 4,263 | 4,293 | 4,630 | 4,885 | 5,127 | 5,471 | 6,485 | 9,517 |
| .0252 | 0.7 | 4,604 | 4,637 | 5,001 | 5,276 | 5,538 | 5,909 | 7,005 | 10,280 |
| .0288 | 0.8 | 4,921 | 4,956 | 5,345 | 5,640 | 5,920 | 6,316 | 7,488 | 10,989 |
| .0324 | 0.9 | 5,219 | 5,256 | 5,669 | 5,981 | 6,278 | 6,699 | 7,942 | 11,655 |
| .0360 | 1.0 | 5,501 | 5,540 | 5,975 | 6,304 | 6,617 | 7,061 | 8,371 | 12,285 |
| .0720 | 2.0 | 7,770 | 7,826 | 8,441 | 8,908 | 9,350 | 9,978 | 11,832 | 17,370 |
| .1080 | 3.0 | 9,505 | 9,573 | 10,328 | 10,899 | 11,442 | 12,212 | 14,483 | 21,269 |
| .1440 | 4.0 | 10,962 | 11,041 | 11,914 | 12,574 | 13,201 | 14,090 | 16,715 | 24,553 |
| .1800 | 5.0 | 12,241 | 12,330 | 13,306 | 14,045 | 14,747 | 15,742 | 18,679 | 27,445 |



Horizontal Valves

| | | Sizes Available | | | | | | | | | | | | | | Ambient Temperature | | |
|--------------------------------------|--------|-----------------|----|--------|--------|----|--------|----|----|---------|--------|----|----|----|----|---|-------|--|
| | | NPT | | | | | | | | Flanged | | | | | | UL -40° to 150° F CA DSA: -10° to 150°F | | |
| | | 3/4" | 1" | 1 1/4" | 1 1/2" | 2" | 2 1/2" | 3" | 4" | 2" | 2 1/2" | 3" | 4" | 6" | 8" | | | |
| Maximum Pressures of Available Sizes | 7 psi | ✓ | ✓ | ✓ | ✓ | | | | | | | | | | | | Fluid | |
| | 60 psi | ✓ | ✓ | ✓ | ✓ | ✓ | ✓ | ✓ | ✓ | ✓ | ✓ | ✓ | ✓ | ✓ | ✓ | Natural gas LP gas | | |

Distributed by Strand Earthquake Consultants / Manufactured by Pacific Seismic Products, Inc.

Tel: (310) 473-2426 or 473-2316. Toll free: (800) 978-7263. Fax: (310) 473-1366. Website: www.strandearthquake.com