

# Specifications: Model 314(60) NPT Valve

## Horizontal Flow

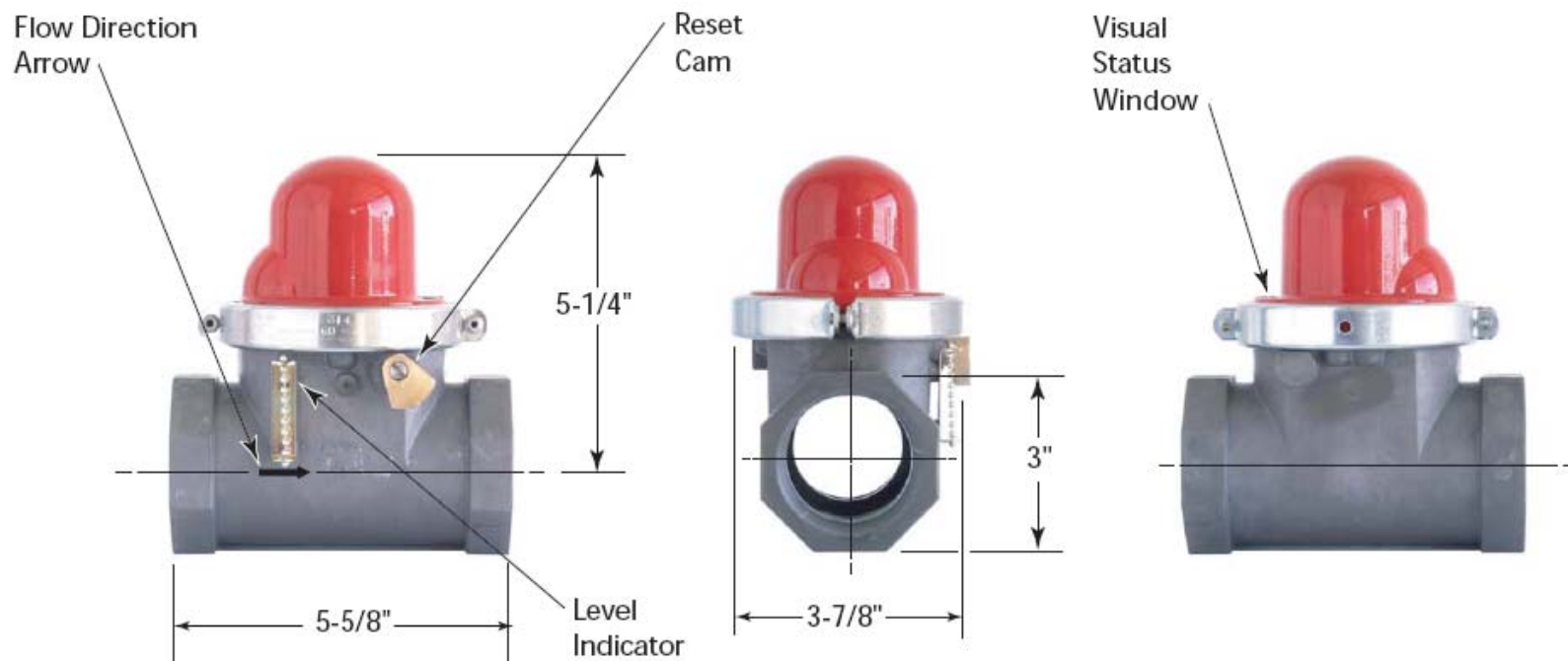

Valve Model#	CA-DSA No.	Length	Height	Octagon	Nominal Pipe Size	Threads Per Inch	APPLICATION	DATA
							Max. Pressure	Fuel
314	45R-113R	5-5/8"	5-1/4"	3-7/8"	2"	11-1/2	60 psi	Dry Fuel Gas

California Valves are UL-listed in the USA & Canada, certified by California's Division of the State Architect, Approved by Los Angeles, and warranted free of manufacturer's defects for 30 years (when used in the USA or Canada). California Valves meet California Standard 12-16-1 for Earthquake Actuated Automatic Gas Shutoff Systems & ASCE Standard 25-97 for Earthquake Actuated Automatic Gas Shutoff Devices.

**Distributed by Strand Earthquake Consultants**  
**Tel: (310) 473-2426 or 473-2316. Toll free: (800) 978-7263**  
**Fax: (310) 473-1366. Website: [www.strandearthquake.com](http://www.strandearthquake.com)**  
**1436 S. Bentley Ave., Suite #6, Los Angeles, CA 90025 USA**  
**Manufactured by Pacific Seismic Products, Inc.**

# 2" Model 314 California Seismic Valve Threaded Horizontal

## FLOW CAPACITY TABLE IWC/PSIG - Capacity S.C.F.H.

Merit Rating: Cv 164 (Equivalent Length of Pipe is 5 Feet)

For determining approximate values at selected natural gas pressures to 60 PSIG

Pressure Drop		8" iwc Inlet	14" iwc Inlet	3 psi Inlet	5 psi Inlet	7 psi Inlet	10 psi Inlet	20 psi Inlet	60 psi Inlet
PSI	IWC								
.0036	0.1	2,828	2,848	3,071	3,240	3,400	3,628	4,300	6,310
.0072	0.2	3,998	4,027	4,342	4,581	4,808	5,130	6,081	8,923
.0108	0.3	4,896	4,931	5,318	5,610	5,889	6,283	7,447	10,928
.0144	0.4	5,653	5,693	6,140	6,478	6,799	7,254	8,599	12,619
.0180	0.5	6,320	6,365	6,864	7,242	7,601	8,110	9,614	14,108
.0216	0.6	6,922	6,971	7,518	7,932	8,326	8,883	10,531	15,454
.0252	0.7	7,476	7,529	8,120	8,567	8,992	9,594	11,374	16,692
.0288	0.8	7,991	8,048	8,680	9,158	9,612	10,256	12,158	17,844
.0324	0.9	8,475	8,535	9,205	9,712	10,194	10,877	12,895	18,925
.0360	1.0	8,932	8,996	9,702	10,237	10,745	11,465	13,592	19,949
.0720	2.0	12,617	12,707	13,707	14,464	15,183	16,202	19,212	28,205
.1080	3.0	15,434	15,545	16,770	17,698	18,580	19,829	23,518	34,536
.1440	4.0	17,800	17,928	19,345	20,417	21,436	22,879	27,142	39,869
.1800	5.0	19,877	20,020	21,606	22,806	23,946	25,561	30,330	44,564



## Horizontal Valves

		Sizes Available														Ambient Temperature	
		NPT								Flanged						UL -40° to 150° F CA DSA: -10° to 150°F	
		3/4"	1"	1 1/4"	1 1/2"	2"	2 1/2"	3"	4"	2"	2 1/2"	3"	4"	6"	8"		
Maximum Pressures of Available Sizes	7 psi	✓	✓	✓	✓												Fluid Natural gas LP gas
	60 psi	✓	✓	✓	✓	✓	✓	✓	✓	✓	✓	✓	✓	✓	✓		

**Distributed by Strand Earthquake Consultants / Manufactured by Pacific Seismic Products, Inc.**

Tel: (310) 473-2426 or 473-2316. Toll free: (800) 978-7263. Fax: (310) 473-1366. Website: [www.strandearthquake.com](http://www.strandearthquake.com)