

Specifications: Model 318(60) NPT Valve

Horizontal Flow

Flow Direction
Arrow

Visual
Status
Window

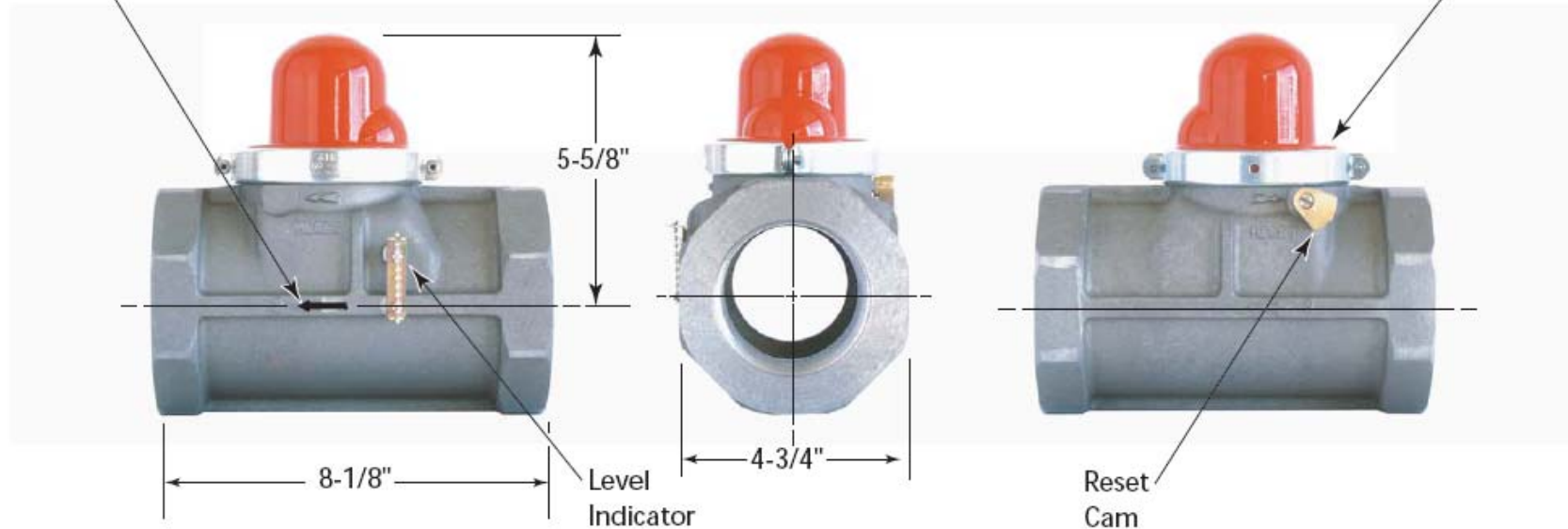

Valve Model#	CA-DSA No.	Length	Height	Octagon	Nominal Pipe Size	Threads Per Inch	APPLICATION	DATA
							Max. Pressure	Fuel
318	62-01	8-1/8"	5-5/8"	4-3/4"	2-1/2"	8	60 psi	Dry Fuel Gas

California Valves are UL-listed in the USA & Canada, certified by California's Division of the State Architect, Approved by Los Angeles, and warranted free of manufacturer's defects for 30 years (when used in the USA or Canada). California Valves meet California Standard 12-16-1 for Earthquake Actuated Automatic Gas Shutoff Systems & ASCE Standard 25-97 for Earthquake Actuated Automatic Gas Shutoff Devices.

Distributed by Strand Earthquake Consultants
Tel: (310) 473-2426 or 473-2316. Toll free: (800) 978-7263
Fax: (310) 473-1366. Website: www.strandearthquake.com
1436 S. Bentley Ave., Suite #6, Los Angeles, CA 90025 USA
Manufactured by Pacific Seismic Products, Inc.

2-1/2" Model 318 California Seismic Valve

Threaded Horizontal

FLOW CAPACITY TABLE IWC/PSIG - Capacity S.C.F.H.

Merit Rating: Cv 236 (Equivalent Length of Pipe is 8 Feet)

For determining approximate values at selected natural gas pressures to 60 PSIG

Pressure Drop		8" iwc Inlet	14" iwc Inlet	3 psi Inlet	5 psi Inlet	7 psi Inlet	10 psi Inlet	20 psi Inlet	60 psi Inlet
PSI	IWC								
.0036	0.1	4,066	4,096	4,419	4,662	4,893	5,221	6,188	9,080
.0072	0.2	5,750	5,791	6,249	6,593	6,919	7,383	8,751	12,841
.0108	0.3	7,041	7,092	7,653	8,074	8,474	9,041	10,717	15,726
.0144	0.4	8,130	8,188	8,835	9,322	9,784	10,439	12,374	18,158
.0180	0.5	9,088	9,154	9,877	10,421	10,938	11,670	13,834	20,301
.0216	0.6	9,954	10,026	10,819	11,415	11,981	12,783	15,154	22,238
.0252	0.7	10,751	10,828	11,685	12,328	12,940	13,806	16,367	24,019
.0288	0.8	11,492	11,574	12,490	13,178	13,832	14,759	17,496	25,677
.0324	0.9	12,187	12,275	13,246	13,976	14,670	15,653	18,557	27,234
.0360	1.0	12,845	12,937	13,962	14,731	15,462	16,498	19,559	28,707
.0720	2.0	18,144	18,274	19,724	20,814	21,849	23,315	27,647	40,588
.1080	3.0	22,194	22,355	24,133	25,468	26,737	28,534	33,842	49,697
.1440	4.0	25,597	25,782	27,838	29,381	30,847	32,924	39,058	57,372
.1800	5.0	28,583	28,791	31,091	32,819	34,459	36,783	43,645	64,128



Horizontal Valves

		Sizes Available														Ambient Temperature
		NPT								Flanged						UL -40° to 150° F CA DSA: -10° to 150°F
		3/4"	1"	1 1/4"	1 1/2"	2"	2 1/2"	3"	4"	2"	2 1/2"	3"	4"	6"	8"	
Maximum Pressures of Available Sizes	7 psi	✓	✓	✓	✓											Fluid Natural gas LP gas
	60 psi	✓	✓	✓	✓	✓	✓	✓	✓	✓	✓	✓	✓	✓		

Distributed by Strand Earthquake Consultants / Manufactured by Pacific Seismic Products, Inc.

Tel: (310) 473-2426 or 473-2316. Toll free: (800) 978-7263. Fax: (310) 473-1366. Website: www.strandearthquake.com