

Specifications: Model VB-319F(60) Flanged Valve

Flanged Vertical - Bottom In - Upward Flow

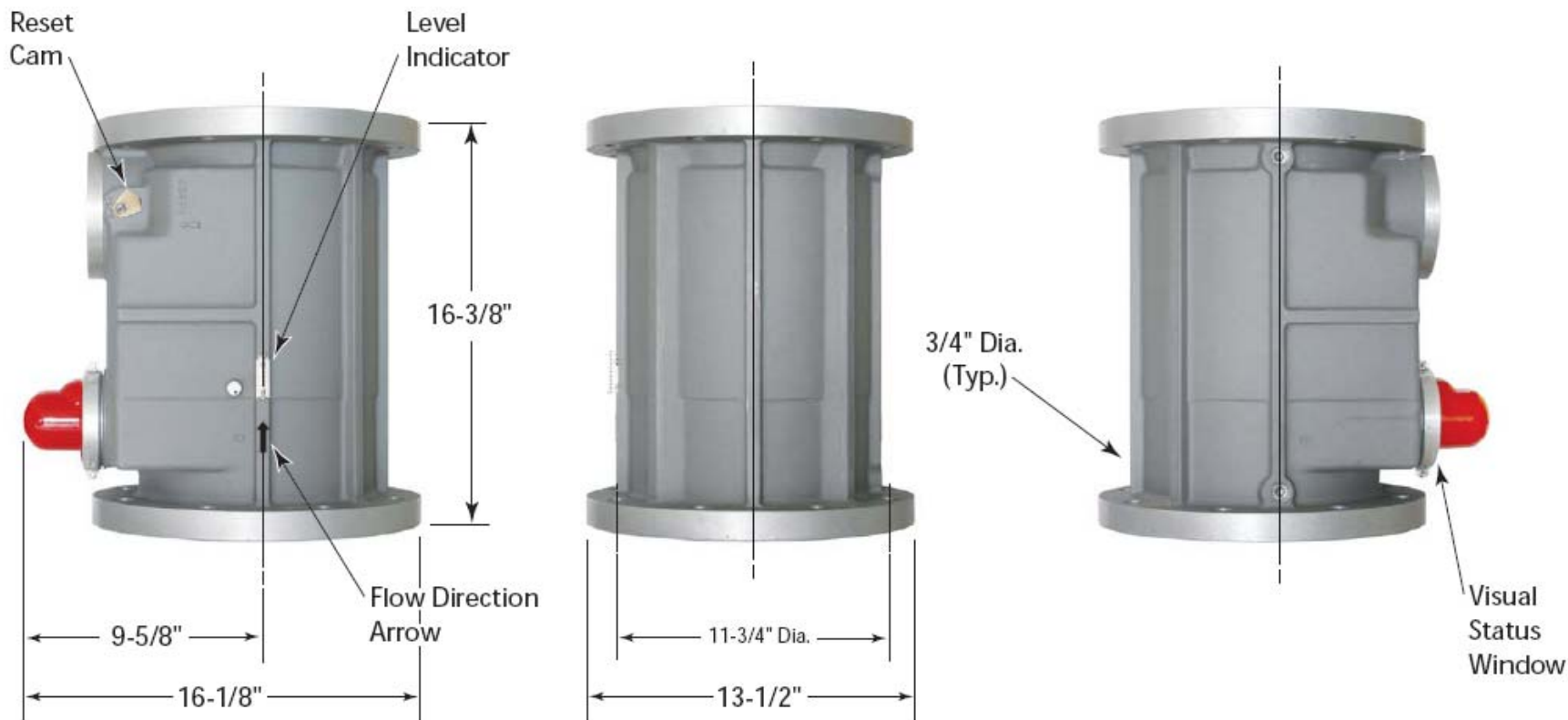

Valve Model#	CA-DSA No.	Length	Height	Diameter	Nominal Pipe Size	APPLICATION	DATA	Diameter On Center	Diameter Hole (Typ.)	Number of Holes
						Max. Pressure	Fuel			
VB-319F	62-02	16-1/8"	16-3/8"	13-1/2"	8"	60 psi	Dry Fuel Gas	11-3/4" Dia.	7/8" Dia.	8

California Valves are UL-listed in the USA & Canada, certified by California's Division of the State Architect, Approved by Los Angeles, and warranted free of manufacturer's defects for 30 years (when used in the USA or Canada). California Valves meet California Standard 12-16-1 for Earthquake Actuated Automatic Gas Shutoff Systems & ASCE Standard 25-97 for Earthquake Actuated Automatic Gas Shutoff Devices.

Distributed by Strand Earthquake Consultants
Tel: (310) 473-2426 or 473-2316. Toll free: (800) 978-7263
Fax: (310) 473-1366. Website: www.strandearthquake.com
1436 S. Bentley Ave., Suite #6, Los Angeles, CA 90025 USA
Manufactured by Pacific Seismic Products, Inc.

8" Model VB-319F California Seismic Valve

Flanged Vertical - Bottom In - Upward Flow

FLOW CAPACITY TABLE IWC/PSIG - Capacity S.C.F.H.

Merit Rating: Cv 3136 (Equivalent Length of Pipe is 9 Feet)

For determining approximate values at selected natural gas pressures to 60 PSIG

Pressure Drop iwc	8" iwc Inlet	14" iwc Inlet	Pressure Drop psi		Pressure Drop psi				
			3 psi Inlet	5 psi Inlet	20 psi Inlet	40 psi Inlet	60 psi Inlet		
0.01	17,089	17,212	0.1	308,644	325,713	1	1,350,644	1,704,995	1,997,442
0.02	24,167	24,340	0.2	435,247	459,451	2	1,881,543	2,388,669	2,805,579
0.03	29,598	29,811	0.3	531,541	561,265	3	2,268,896	2,897,618	3,412,403
0.04	34,167	34,422	0.4	612,004	646,420	4	2,578,236	3,313,362	3,912,728
0.05	38,210	38,484	0.5	682,260	720,845	5	2,835,213	3,667,734	4,343,513
0.06	41,856	42,157	0.6	745,202	787,586	6	3,053,079	3,977,172	4,723,822
0.07	45,209	45,534	0.7	802,553	848,460	7	3,239,733	4,251,499	5,065,038
0.08	48,330	48,677	0.8	855,437	904,651	8	3,400,320	4,497,145	5,374,611
0.09	51,261	51,630	0.9	904,639	956,985	9	3,538,390	4,718,591	5,657,739
0.1	54,034	54,422	1.0	950,730	1,006,064	10	3,656,495	4,919,108	5,918,217
0.2	76,406	76,955	1.1	994,144	1,052,343	11	3,756,518	5,101,163	6,158,920
0.3	93,566	94,239	1.2	1,035,216	1,096,177	12	3,839,873	5,266,671	6,382,087
0.4	108,028	108,805	1.3	1,074,216	1,137,849	13		5,417,150	6,589,498
0.5	120,765	121,633	1.4	1,111,362	1,177,588	14		5,553,821	6,782,600
0.6		133,227	1.5	1,146,834	1,215,584	15		5,677,681	6,962,583
0.7		143,884	1.6	1,180,783	1,251,995	16		5,789,552	7,130,441
0.8		153,800	1.7	1,213,337	1,286,956	17		5,890,118	7,287,011
0.9		163,111	1.8	1,244,604	1,320,582	18		5,979,950	7,433,008
1.0		171,913	1.9	1,274,681	1,352,973	19		6,059,523	7,569,042
2.0		242,833	2.0	1,303,649	1,384,216	20		6,129,239	7,695,642
3.0		297,055	2.1		1,414,386	21		6,189,430	7,813,268
4.0		342,600	2.2		1,443,551	22		6,240,372	7,922,318
5.0		382,580	2.3		1,471,770	23		6,282,290	8,023,142
			2.4		1,499,097	24		6,315,363	8,116,047
			2.5		1,525,580	25		6,339,730	8,201,302
			2.6		1,551,262				
			2.7		1,576,182				



Vertical Valves

Maximum Pressures of Available Sizes	7 psi	Sizes Available												Ambient Temperature UL -40° to 150° F CA DSA: -10° to 150°F Fluid Natural gas LP gas	
		NPT								Flanged					
		3/4"	1"	1 1/4"	1 1/2"	2"	2 1/2"	3"	4"	2"	2 1/2"	3"	4"		6"
60 psi	✓	✓	✓	✓	✓	✓	✓	✓	✓	✓	✓	✓	✓	✓	✓

Distributed by Strand Earthquake Consultants / Manufactured by Pacific Seismic Products, Inc.

Tel: (310) 473-2426 or 473-2316. Toll free: (800) 978-7263. Fax: (310) 473-1366. Website: www.strandearthquake.com