

Specifications: Model VT-300 NPT Valve

Vertical - Top In Flow

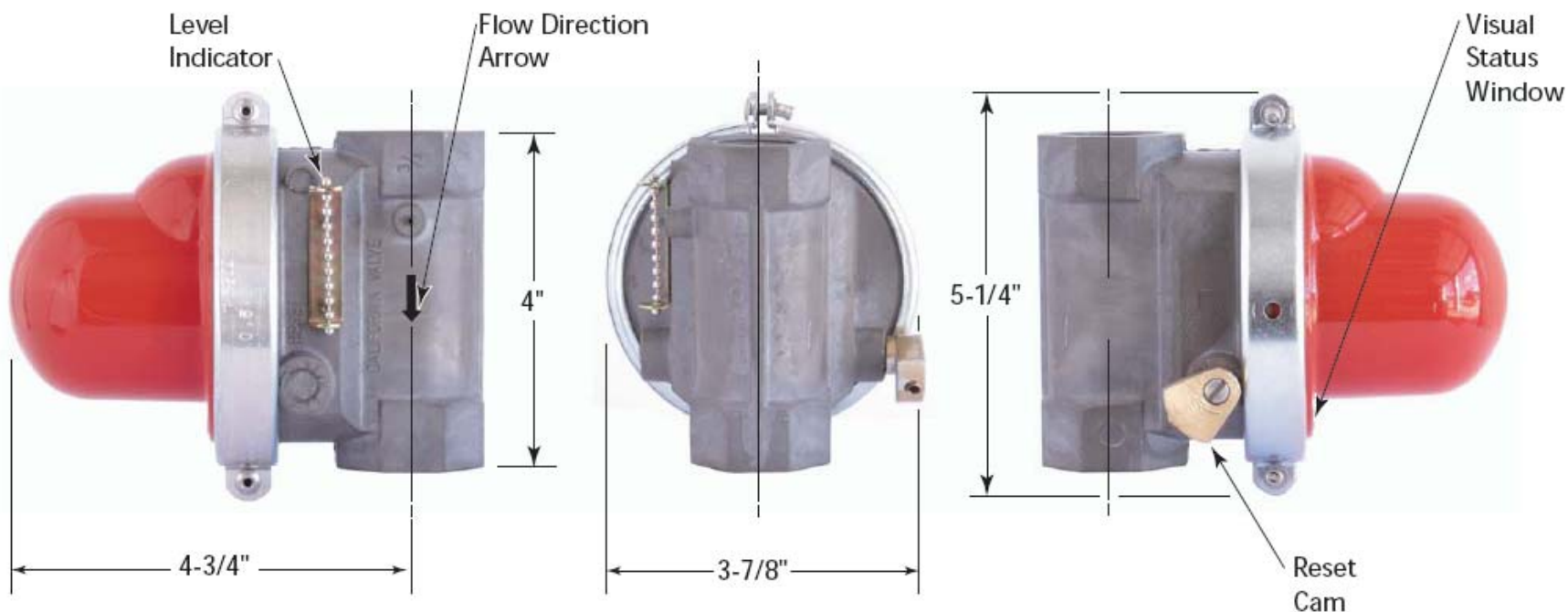

Valve Model#	CA-DSA No.	Length	Height	Width	Nominal Pipe Size	Threads Per Inch	APPLICATION DATA	
							Max. Pressure	Fuel
VT-300	60-03	4-3/4"	5-1/4"	3-7/8"	3/4"	14	7.0 psi	Dry Fuel Gas

California Valves are UL-listed in the USA & Canada, certified by California's Division of the State Architect, Approved by Los Angeles, and warranted free of manufacturer's defects for 30 years (when used in the USA or Canada). California Valves meet California Standard 12-16-1 for Earthquake Actuated Automatic Gas Shutoff Systems & ASCE Standard 25-97 for Earthquake Actuated Automatic Gas Shutoff Devices.

Distributed by Strand Earthquake Consultants
Tel: (310) 473-2426 or 473-2316. Toll free: (800) 978-7263
Fax: (310) 473-1366. Website: www.strandearthquake.com
1436 S. Bentley Ave., Suite #6, Los Angeles, CA 90025 USA
Manufactured by Pacific Seismic Products, Inc.

3/4" Model VT-300 California Seismic Valve

Threaded Vertical - Downward Flow

FLOW CAPACITY TABLE IWC/PSIG - Capacity S.C.F.H.

Merit Rating: Cv 21 (Equivalent Length of Pipe is 3 Feet)

For determining approximate values at selected natural gas pressures to

Pressure Drop		8" iwc Inlet	14" iwc Inlet	3 psi Inlet	5 psi Inlet	7 psi Inlet	10 psi Inlet	20 psi Inlet	60 psi Inlet
PSI	IWC								
.0036	0.1	362	365	393	415	435	465	551	808
.0072	0.2	512	516	556	587	616	657	779	1,143
.0108	0.3	627	631	681	718	754	804	954	1,399
.0144	0.4	724	729	786	829	871	929	1,101	1,616
.0180	0.5	809	815	879	927	973	1,038	1,231	1,806
.0216	0.6	886	893	963	1,016	1,066	1,137	1,348	1,979
.0252	0.7	957	964	1,040	1,097	1,151	1,229	1,456	2,137
.0288	0.8	1,023	1,031	1,111	1,173	1,231	1,313	1,557	2,285
.0324	0.9	1,085	1,093	1,179	1,244	1,305	1,393	1,651	2,423
.0360	1.0	1,144	1,152	1,242	1,311	1,376	1,468	1,740	2,554
.0720	2.0	1,616	1,627	1,755	1,852	1,944	2,075	2,460	3,612
.1080	3.0	1,976	1,990	2,147	2,286	2,379	2,539	3,011	4,422
.1440	4.0	2,279	2,296	2,477	2,614	2,745	2,930	3,475	5,105
.1800	5.0	2,545	2,564	2,767	2,920	3,066	3,273	3,884	5,706



Vertical Valves

		Sizes Available														Ambient Temperature		
		NPT								Flanged						UL -40° to 150° F CA DSA: -10° to 150°F	Fluid	
		3/4"	1"	1 1/4"	1 1/2"	2"	2 1/2"	3"	4"	2"	2 1/2"	3"	4"	6"	8"			
Maximum Pressures of Available Sizes	7 psi	✓	✓	✓	✓													
	60 psi	✓	✓	✓	✓	✓	✓	✓	✓	✓	✓	✓	✓	✓	✓			
																	Natural gas	LP gas

Distributed by Strand Earthquake Consultants / Manufactured by Pacific Seismic Products, Inc.

Tel: (310) 473-2426 or 473-2316. Toll free: (800) 978-7263. Fax: (310) 473-1366. Website: www.strandearthquake.com