

# Specifications: Model VT-311(60) NPT Valve

## Vertical - Top In Flow

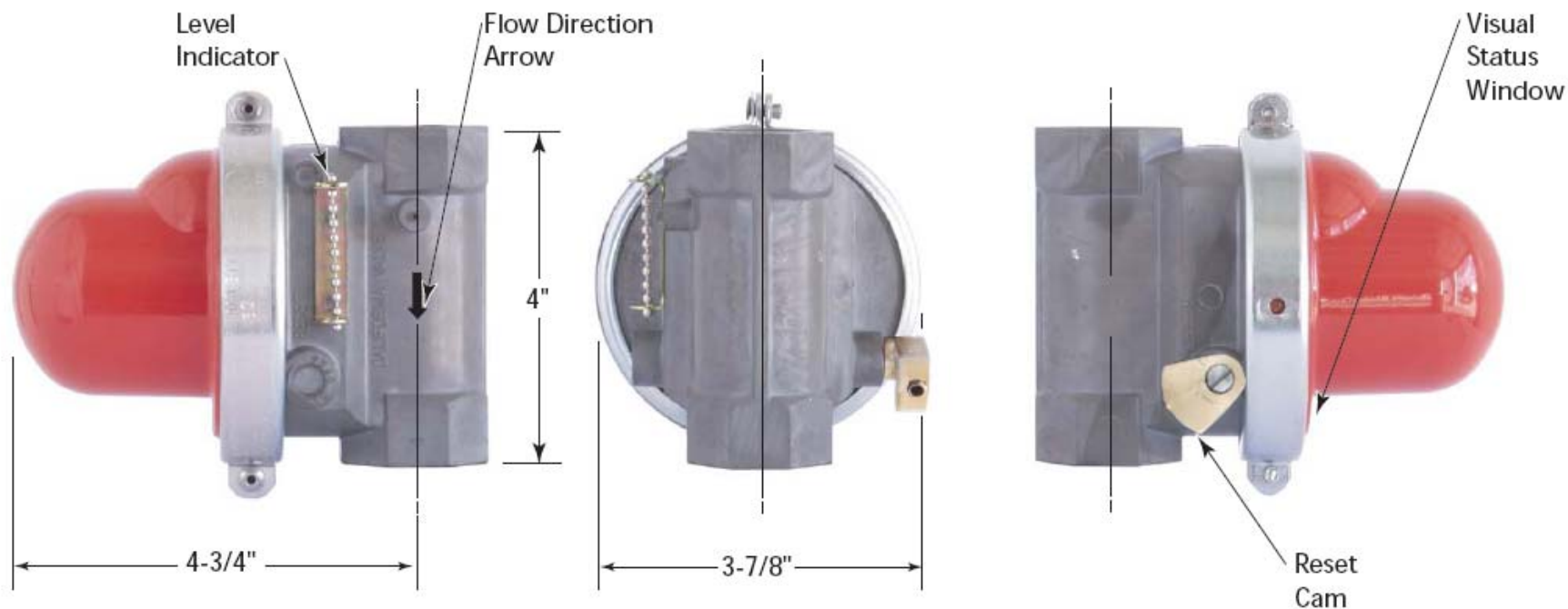

Valve Model#	CA-DSA No.	Length	Height	Width	Nominal Pipe Size	Threads Per Inch	APPLICATION	DATA
							Max. Pressure	Fuel
VT-311	60-03	4-3/4"	4"	3-7/8"	1"	11-1/2	60 psi	Dry Fuel Gas

California Valves are UL-listed in the USA & Canada, certified by California's Division of the State Architect, Approved by Los Angeles, and warranted free of manufacturer's defects for 30 years (when used in the USA or Canada). California Valves meet California Standard 12-16-1 for Earthquake Actuated Automatic Gas Shutoff Systems & ASCE Standard 25-97 for Earthquake Actuated Automatic Gas Shutoff Devices.

**Distributed by Strand Earthquake Consultants**  
**Tel: (310) 473-2426 or 473-2316. Toll free: (800) 978-7263**  
**Fax: (310) 473-1366. Website: [www.strandearthquake.com](http://www.strandearthquake.com)**  
**1436 S. Bentley Ave., Suite #6, Los Angeles, CA 90025 USA**  
**Manufactured by Pacific Seismic Products, Inc.**

# 1" Model VT-311 California Seismic Valve

## Threaded Vertical - Downward Flow

### FLOW CAPACITY TABLE IWC/PSIG - Capacity S.C.F.H.

Merit Rating: Cv 41 (Equivalent Length of Pipe is 3 Feet)

For determining approximate values at selected natural gas pressures to 60 PSIG

Pressure Drop		8" iwc Inlet	14" iwc Inlet	3 psi Inlet	5 psi Inlet	7 psi Inlet	10 psi Inlet	20 psi Inlet	60 psi Inlet
PSI	IWC								
.0036	0.1	707	712	768	810	850	907	1,075	1,577
.0072	0.2	1,000	1,007	1,086	1,145	1,202	1,283	1,520	2,231
.0108	0.3	1,224	1,233	1,329	1,403	1,472	1,571	1,862	2,732
.0144	0.4	1,413	1,423	1,535	1,619	1,700	1,814	2,150	3,155
.0180	0.5	1,580	1,591	1,716	1,810	1,900	2,027	2,403	3,527
.0216	0.6	1,731	1,743	1,880	1,983	2,081	2,221	2,633	3,863
.0252	0.7	1,869	1,882	2,030	2,142	2,248	2,399	2,843	4,173
.0288	0.8	1,998	2,012	2,170	2,289	2,403	2,564	3,040	4,461
.0324	0.9	2,119	2,134	2,301	2,428	2,549	2,719	3,224	4,731
.0360	1.0	2,233	2,249	2,426	2,559	2,686	2,866	3,398	4,987
.0720	2.0	3,154	3,177	3,427	3,616	3,796	4,050	4,803	7,051
.1080	3.0	3,858	3,886	4,193	4,425	4,645	4,957	5,879	8,634
.1440	4.0	4,450	4,482	4,836	5,104	5,359	5,720	6,785	9,967
.1800	5.0	4,969	5,005	5,401	5,702	5,987	6,390	7,582	11,141



### Vertical Valves

Maximum Pressures of Available Sizes		Sizes Available														Ambient Temperature	
		NPT								Flanged						UL -40° to 150° F CA DSA: -10° to 150°F	Fluid
		3/4"	1"	1 1/4"	1 1/2"	2"	2 1/2"	3"	4"	2"	2 1/2"	3"	4"	6"	8"		
7 psi	✓	✓	✓	✓													
60 psi	✓	✓	✓	✓	✓	✓	✓	✓	✓	✓	✓	✓	✓	✓	✓		
Natural gas LP gas																	

Distributed by Strand Earthquake Consultants / Manufactured by Pacific Seismic Products, Inc.

Tel: (310) 473-2426 or 473-2316. Toll free: (800) 978-7263. Fax: (310) 473-1366. Website: [www.strandearthquake.com](http://www.strandearthquake.com)