

Specifications: Model VT-317F(60) Flanged Valve

Vertical - Top In Flow

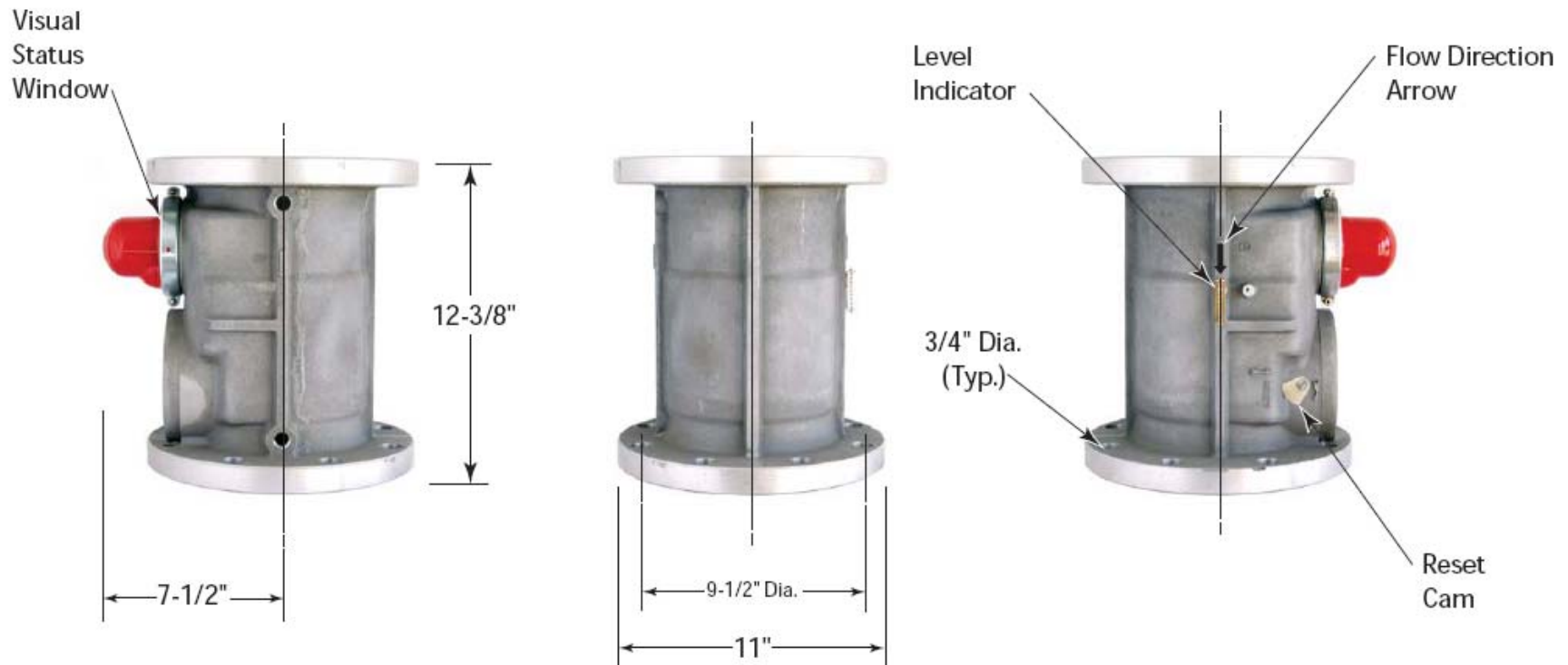

| Valve Model# | CA-DSA No. | Length | Height | Diameter | Nominal Pipe Size | APPLICATION | DATA | Diameter On Center | Diameter Hole (Typ.) | Number of Holes |
|--------------|------------|--------|---------|----------|-------------------|---------------|--------------|--------------------|----------------------|-----------------|
| | | | | | | Max. Pressure | Fuel | | | |
| VT-317F | 60-05 | 7-1/2" | 12-3/8" | 11" | 6" | 60 psi | Dry Fuel Gas | 9-1/2" Dia. | 3/4" Dia. | 8 |

California Valves are UL-listed in the USA & Canada, certified by California's Division of the State Architect, Approved by Los Angeles, and warranted free of manufacturer's defects for 30 years (when used in the USA or Canada). California Valves meet California Standard 12-16-1 for Earthquake Actuated Automatic Gas Shutoff Systems & ASCE Standard 25-97 for Earthquake Actuated Automatic Gas Shutoff Devices.

Distributed by Strand Earthquake Consultants
Tel: (310) 473-2426 or 473-2316. Toll free: (800) 978-7263
Fax: (310) 473-1366. Website: www.strandearthquake.com
1436 S. Bentley Ave., Suite #6, Los Angeles, CA 90025 USA
Manufactured by Pacific Seismic Products, Inc.

6" Model VT-317F California Seismic Valve

Flanged Vertical - Downward Flow

FLOW CAPACITY TABLE IWC/PSIG - Capacity S.C.F.H.

Merit Rating: Cv 1769

For determining approximate values at selected natural gas pressures to 60 PSIG

| Pressure Drop | | | | | | | | | |
|---------------|--------------|---------------|--------|-------------|-------------|--------|--------------|--------------|--------------|
| PD iwc | 8" iwc Inlet | 14" iwc Inlet | PD psi | 3 psi Inlet | 5 psi Inlet | PD psi | 20 psi Inlet | 40 psi Inlet | 60 psi Inlet |
| 0.01 | 9,312 | 9,379 | 0.1 | 174,102 | 183,730 | 1 | 761,878 | 961,762 | 1,126,727 |
| 0.02 | 13,169 | 13,264 | 0.2 | 245,516 | 259,169 | 2 | 1,061,350 | 1,347,412 | 1,582,585 |
| 0.03 | 16,128 | 16,245 | 0.3 | 299,834 | 316,601 | 3 | 1,279,851 | 1,634,503 | 1,824,885 |
| 0.04 | 18,623 | 18,757 | 0.4 | 345,222 | 364,636 | 4 | 1,454,344 | 1,869,018 | 2,207,111 |
| 0.05 | 20,821 | 20,971 | 0.5 | 384,853 | 406,618 | 5 | 1,599,302 | 2,068,914 | 2,450,111 |
| 0.06 | 22,808 | 22,973 | 0.6 | 420,357 | 444,266 | 6 | 1,722,196 | 2,243,463 | 2,664,638 |
| 0.07 | 24,636 | 24,813 | 0.7 | 452,708 | 478,604 | 7 | 1,827,485 | 2,398,207 | 2,857,112 |
| 0.08 | 26,336 | 26,526 | 0.8 | 482,539 | 510,300 | 8 | 1,918,070 | 2,536,772 | 3,031,738 |
| 0.09 | 27,934 | 28,135 | 0.9 | 510,293 | 539,821 | 9 | 1,995,953 | 2,661,687 | 3,191,446 |
| 0.1 | 29,444 | 29,656 | 1.0 | 536,293 | 567,506 | 10 | 2,062,574 | 2,774,795 | 3,338,378 |
| 0.2 | 41,636 | 41,936 | 1.1 | 560,782 | 593,611 | 11 | 2,118,996 | 2,877,490 | 3,474,155 |
| 0.3 | 50,987 | 51,354 | 1.2 | 583,950 | 618,337 | 12 | 2,166,015 | 2,970,851 | 3,600,040 |
| 0.4 | 58,868 | 59,292 | 1.3 | 605,949 | 641,844 | 13 | | 3,055,733 | 3,717,037 |
| 0.5 | 65,808 | 66,283 | 1.4 | 626,903 | 664,260 | 14 | | 3,132,827 | 3,825,563 |
| 0.6 | | 72,600 | 1.5 | 646,912 | 685,893 | 15 | | 3,202,695 | 3,927,489 |
| 0.7 | | 78,206 | 1.6 | 666,062 | 706,232 | 16 | | 3,265,800 | 4,022,175 |
| 0.8 | | 83,812 | 1.7 | 684,452 | 725,953 | 17 | | 3,322,528 | 4,110,494 |
| 0.9 | | 88,885 | 1.8 | 702,063 | 744,921 | 18 | | 3,373,200 | 4,192,849 |
| 1.0 | | 93,682 | 1.9 | 719,028 | 763,192 | 19 | | 3,418,087 | 4,269,584 |
| 2.0 | | 132,329 | 2.0 | 735,369 | 780,816 | 20 | | 3,457,412 | 4,340,997 |
| 3.0 | | 161,876 | 2.1 | | 797,834 | 21 | | 3,491,365 | 4,407,348 |
| 4.0 | | 186,695 | 2.2 | | 814,285 | 22 | | 3,520,101 | 4,468,861 |
| | | | 2.3 | | 830,203 | 23 | | 3,543,746 | 4,525,734 |
| | | | 2.4 | | 845,618 | 24 | | 3,562,402 | 4,578,141 |
| | | | 2.5 | | 860,557 | 25 | | 3,576,147 | 4,626,232 |
| | | | 2.6 | | 875,044 | | | | |
| | | | 2.7 | | 889,101 | | | | |



Vertical Valves

| | | Sizes Available | | | | | | | | | | | | | | Ambient Temperature | |
|--------------------------------------|--------|-----------------|----|--------|--------|----|--------|----|----|---------|--------|----|----|----|----|---------------------|-----------------------|
| | | NPT | | | | | | | | Flanged | | | | | | | |
| | | 3/4" | 1" | 1 1/4" | 1 1/2" | 2" | 2 1/2" | 3" | 4" | 2" | 2 1/2" | 3" | 4" | 6" | 8" | UL -40° to 150° F | CA DSA: -10° to 150°F |
| Maximum Pressures of Available Sizes | 7 psi | ✓ | ✓ | ✓ | ✓ | | | | | | | | | | | | |
| | 60 psi | ✓ | ✓ | ✓ | ✓ | ✓ | ✓ | ✓ | ✓ | ✓ | ✓ | ✓ | ✓ | ✓ | | | |
| | | | | | | | | | | | | | | | | Fluid | |
| | | | | | | | | | | | | | | | | Natural gas | |
| | | | | | | | | | | | | | | | | LP gas | |

Distributed by Strand Earthquake Consultants / Manufactured by Pacific Seismic Products, Inc.

Tel: (310) 473-2426 or 473-2316. Toll free: (800) 978-7263. Fax: (310) 473-1366. Website: www.strandearthquake.com